



**Agenda**  
**Board of Selectmen's Meeting**  
**Town of Damariscotta, Maine**  
**November 3, 2021; 5:30 PM**  
**Damariscotta Town Hall**

- I. Pledge of Allegiance**
- II. Call to Order**
- III. Minutes**
  - 1. October 6 and 20 Meetings
- IV. Financial Reports**
  - 1. Payroll Warrant #
  - 2. Accounts Payable Warrants #'s
- V. Presentations**
  - 1. Presentation on Shellfish Resilience Project- Sarah Risley, Darling Center
  - 2. Review of Waterfront Improvement Project 60% Design Drawings- Wright Pierce and SLR Consultants
  - 3. Selectmen's Report on Waterfront Project Historic Elements Focus Group Meeting
  - 4. Selectmen's Report on CLC Ambulance Budget Meeting
  - 5. Selectman's Report Lincoln County Budget Process
- VI. Citizen Comments and General Correspondence**
  - 1. Request for Board resolution on Proposed Amendment to State Constitution Re: Right to Clean Air, Clean Water and Healthy Environment- Audrey Hufnagel
- VII. Town Manager Items**
  - 1. Key Items from October 28 Meeting with Maine Department of Transportation staff
- VIII. Official Action Items**
  - 1. Agreement with Maine Department of Transportation re: Information Bureau Property (tentative)
  - 2. Confirmation of Town Manager's Appointment of Assessors' Agent
  - 3. Confirmation of Town Manager's Appointment of Interim Code Enforcement Officer
  - 4. Comprehensive Plan Committee Appointments
  - 5. Contracts for Fuel Oil and Propane
- IX. Selectmen's Discussion Items**
- X. Adjournment**

# Town Manager Notes for November 3, 2021 Board of Selectmen's Meeting

## Presentations

1. **Presentation on Shellfish Resilience Project-** Sarah Risley, the project manager for the Towns' (Damariscotta, Newcastle and Bremen) Shellfish Resource Grant, will be providing the Board with an update on the project.
2. **Review of Waterfront Improvement Project 60% Design Drawings-** Jan Wiegman from Wright Pierce and Mike Zarba from SLR Consultants will be reviewing the 60% design plans for the balance of the improvements in the Waterfront Project. The presentation will be made via Zoom. Attached is an email that contains the links to a number of documents that are part of this phase of the design work. Please let me know if you have any difficulty opening these documents.
3. **Selectmen's Report on Waterfront Project Historic Elements Focus Group Meeting –** Selectmen Abbotoni and Anderson will have attended the Focus Group meeting on Monday morning.
4. **Selectmen's Report on CLC Ambulance Budget Meeting-** Selectmen Anderson and Pinkham attended the Ambulance Service's Budget Meeting on October 25.
5. **Selectman's Report Lincoln County Budget Process –** Selectman Abbotoni is the Town's representative and a representative for County District 3 on the County Budget Committee.

## Citizen Comments and General Correspondence

1. **Request for Board resolution on Proposed Amendment to State Constitution Re: Right to Clean Air, Clean Water and Healthy Environment-** Audrey Hufnagel is requesting that the Board take formal action in support of this legislation sponsored by State Senator Maxmin. Attached is Audrey's request and the thread of emails between her and me.

## Town Manager Items

1. **Key Items from October 28 Meeting with Maine Department of Transportation staff –** Last Tuesday, Selectmen Anderson and Hagar, Police Chief Jason Warlick and I met with staff from the

Maine Department of Transportation's Traffic Safety Division. The main discussion item was the intersection of Belvedere Road and Extension with US 1 Bypass. The number and severity of accidents at this intersection have been a major concern for decades. Although some intermediate steps have been taken to address the safety issues, this continues to be one of the worst rural intersections in the State. During the meeting the MDOT staff reviewed a number of alternatives and their plan for a solution. The Department has included in the third year (2024) of their three-year plan the construction of a \$3.1 million roundabout at the intersection. The analysis conducted by the Department shows that there will be a significant reduction in the number of accidents with this improvement with minimal impact on what the analysts refer to as the mobility factor. When asked what the Town could do to sport the project, the Department staff indicated that a letter from the Selectmen would be helpful at this point.

Two other intersections that the Town has asked to have reviewed - the intersection of School Street and Main Street (US 1 B) and School Street and Bristol Road -were also addressed during this meeting. Selectmen Hagar and Anderson and I can provide the Board with a verbal update on those potential projects at Wednesday's meeting.

## Official Action Items

1. **Agreement with Maine Department of Transportation re: Information Bureau Property** (tentative) Town and Chamber staff are currently reviewing a draft deed and license agreement that we received last Friday.
2. **Confirmation of Town Manager's Appointment of Assessors' Agent** – Selectmen acting in their capacity as the Town's assessors and I met with two assessing agent candidates on Wednesday. I am in the process of following up on the decision of the panel and will be in a position to share that with you prior to next Wednesday's meeting.  
**Recommended Action: Confirm the Town Manager's appointment for Assessors' agent.**
3. **Confirmation of Town Manager's Appointment of Interim Code Enforcement Officer**- Joe Rose, the Code Enforcement Officer for the Town of Bristol has agreed to serve as the interim CEO for Damariscotta as we continue to recruit for a replacement for Stan Waltz whose last day working for Damariscotta was last Thursday. As the Board is aware, Town staff have been engaged in the recruitment for this position since shortly after Stan submitted his letter of resignation six weeks ago.  
**Recommended Action: Confirm the Town Manager's appointment of Joe Rose as the interim Code Enforcement Officer.**
4. **Comprehensive Plan Committee Appointments** I will be asking you to make one or more additional appointments at Wednesday's meeting.
5. **Contracts for Fuel Oil and Propane**- I have not received this from Colby and Gale yet.

BID SET No. \_\_\_\_\_

# TOWN OF DAMARISCOTTA, MAINE

## CONTRACT DRAWINGS FOR

# DOWNTOWN FLOOD PROTECTION IMPROVEMENTS

### OCTOBER 2021

### 60% DESIGN SUBMISSION

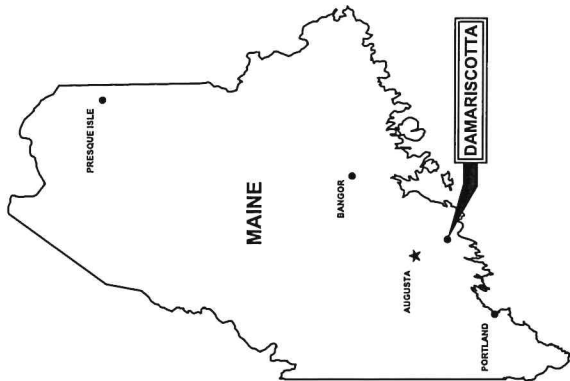

DRAWING INDEX

GENERAL	
—	
<u>CIVIL</u>	
C-1	GENERAL NOTES, LEGEND & ABBREVIATIONS
C-2	EXISTING CONDITIONS & DEMOLITION PLAN
C-3	PROPOSED SITE LAYOUT PLAN
C-4	PROPOSED GRADING & DRAINAGE PLAN
C-5	PROPOSED SITE UTILITY PLAN
C-6	FLOOD WALL PROFILE
C-7	DETAILS I
C-8	DETAILS II
C-9	DETAILS III
C-10	EROSION CONTROL NOTES & DETAILS

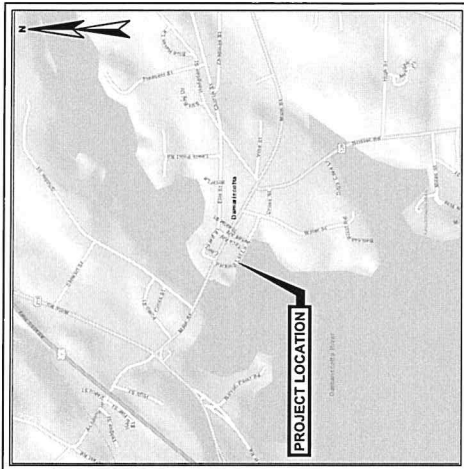

LOCATION PLAN  
SCALE: N/A



**WRIGHT-PIERCE**  
Engineering a Better Environment  
(207) 725-8721 | [www.wright-pierce.com](http://www.wright-pierce.com)

FOR REVIEW    OCTOBER 29, 2021  
FOR BIDDING  
WP PROJECT No. 20459





PROJECT NO.	2493		
DESIGNED BY	LANDRUM		
CHECKED BY	REINER		
DATE	8/20/21		
APPROVED BY	LANDRUM		
DATE	10/29/21		
REVISIONS			
NO.		DATE	

REVISIONS			
NO.		DATE	

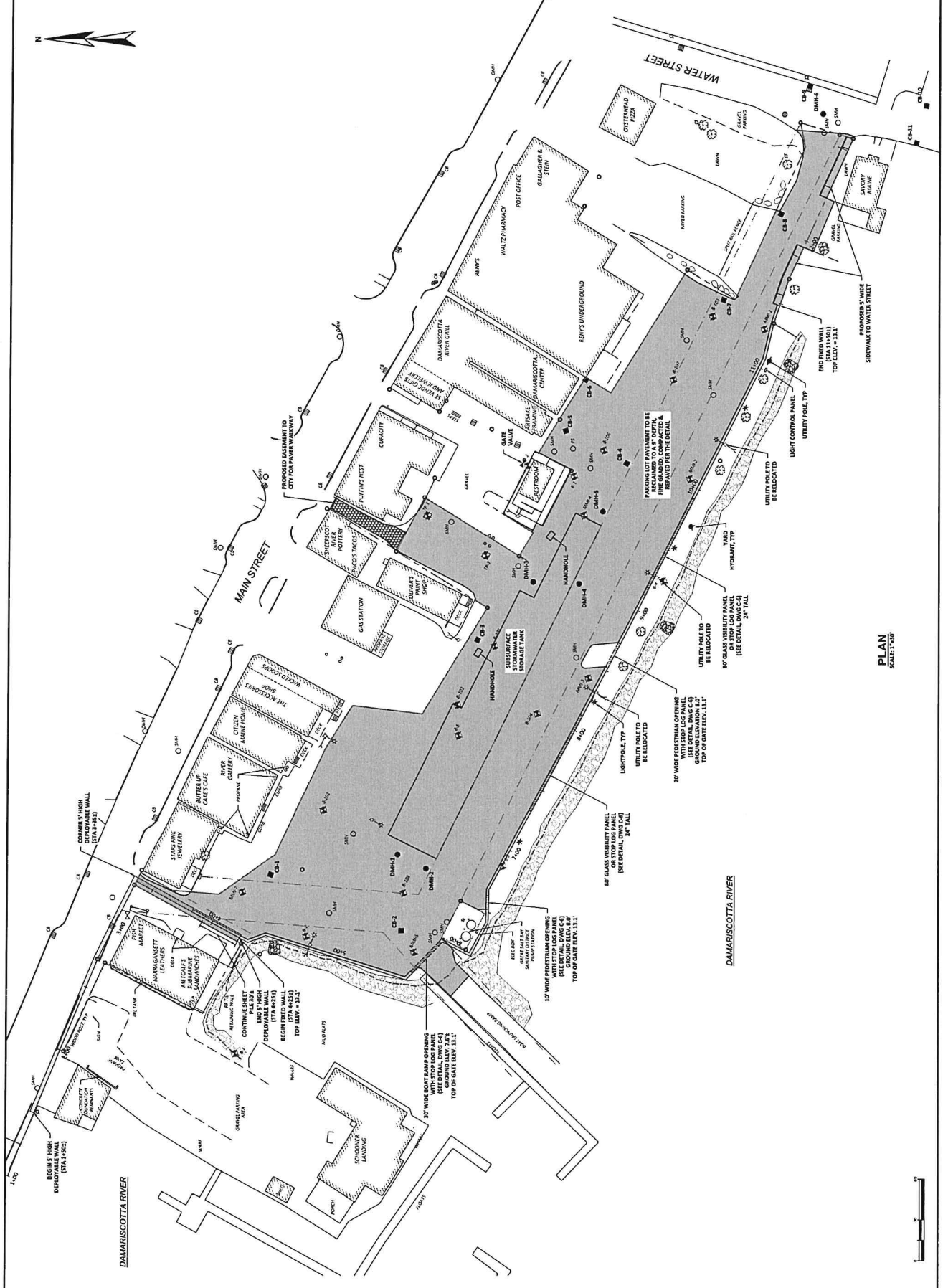

PLAN SCALE: 1"=10'



TOWN OF DAMARISCOTTA  
STORMWATER IMPROVEMENTS  
DAMARISCOTTA, MAINE

WRIGHT-PIERCE  
11 ROYCE HILL ROAD, TOPSHAM, ME 05089  
(207) 725-8723 | WWW.WRIGHT-PIERCE.COM

NO	REVISIONS	DATE	BY

PROJECT NO:	2023
DESIGNED BY:	LAWRENCE
CHECKED BY:	LAWRENCE
DATE:	10/24/23
APPROVED BY:	LAWRENCE
DATE:	10/24/23
ISSUED FOR:	FOR DESIGN SUBMISSION



PLAN  
SCALE 1\"/>







TOWN OF DAMARISCOTTA  
STORMWATER IMPROVEMENTS  
DAMARISCOTTA, MAINE

FLOOD WALL PROFILE

**WRIGHT-PIERCE**  
(207) 725-8723 | www.wright-pierce.com

11 BROWN HILL ROAD, TOPSHAM, ME 05088

PROJECT NO: 2015  
SHEET NO: 10  
DATE: 10/21/15  
DRAWN BY: [Name]  
CHECKED BY: [Name]  
SCALE: AS SHOWN

NO	REVISIONS	APPD DATE

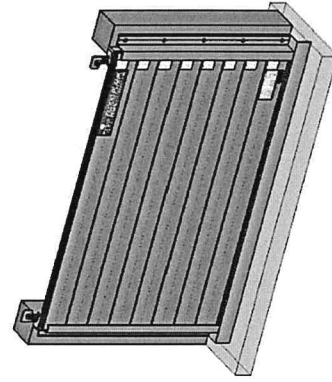

**STOP LOG PANEL**  
SCALE: 1/8"=1'-0"



**GLASS VISIBILITY PANEL**  
SCALE: 1/8"=1'-0"

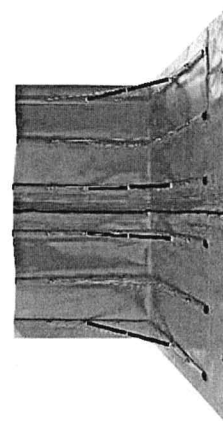

**5' HIGH DEPLOYABLE WALL**  
SCALE: 1/8"=1'-0"

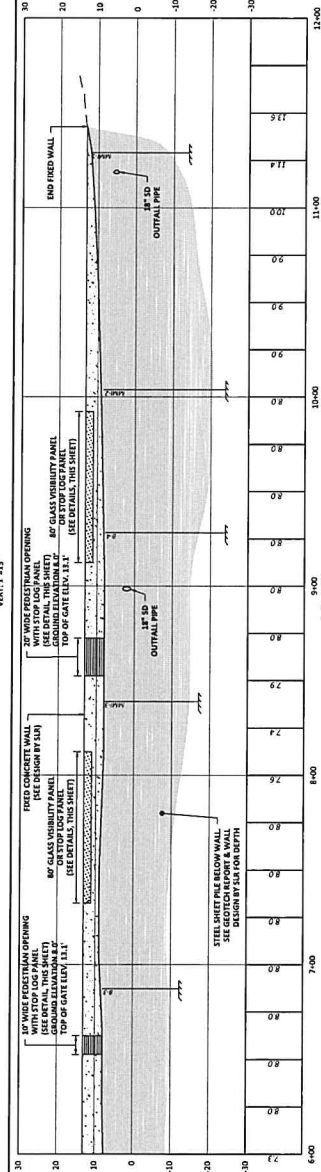

**PROFILE**  
SCALE: 1"=30'  
VERT: 1"=15'

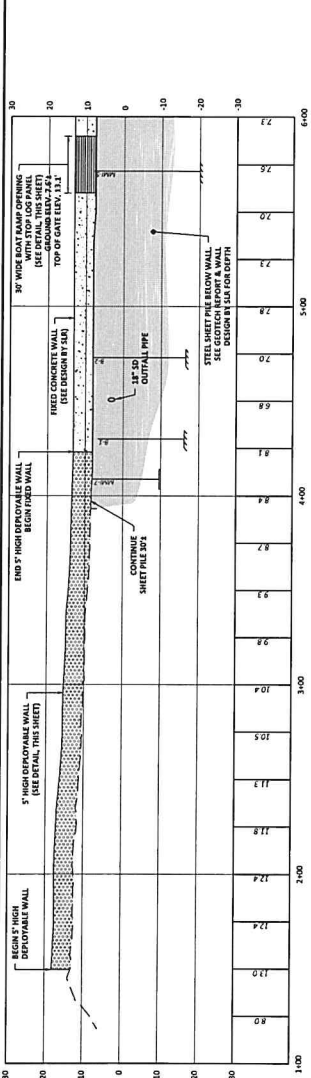

**PROFILE**  
SCALE: 1"=30'  
VERT: 1"=15'

PROJECT NO: 2019

DESIGNER: LAYSEMAN

DATE: 10/21/19

APPROVED: LAYSEMAN

DATE: 10/21/19

DESIGNER: LAYSEMAN

DATE: 10/21/19

APPROVED: LAYSEMAN

DATE: 10/21/19

NO

REVISIONS

APPD DATE

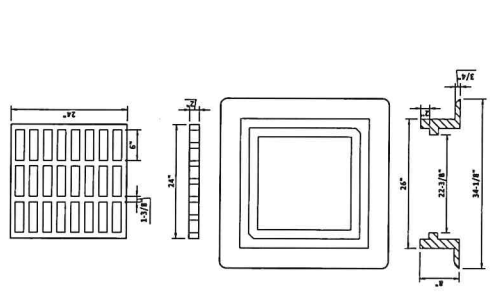

FRAME AND COVER  
FOR TYPE A 4' CATCH BASIN  
SCALE: 1/2" = 1'-0"

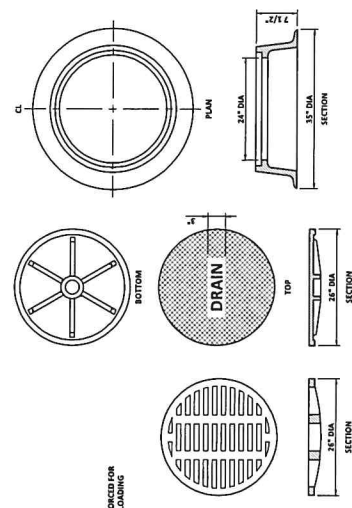

CATCH BASIN & MANHOLE  
STANDARD COVER AND FRAME  
SCALE: 1/2" = 1'-0"

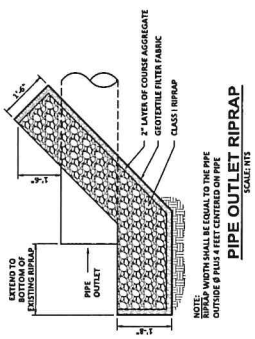

PIPE OUTLET RIPRAP  
SCALE: 1/2" = 1'-0"

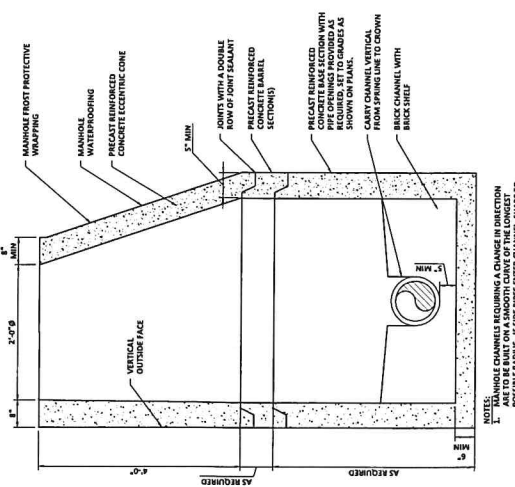

TYPICAL 4-FT MANHOLE  
SCALE: 1/2" = 1'-0"

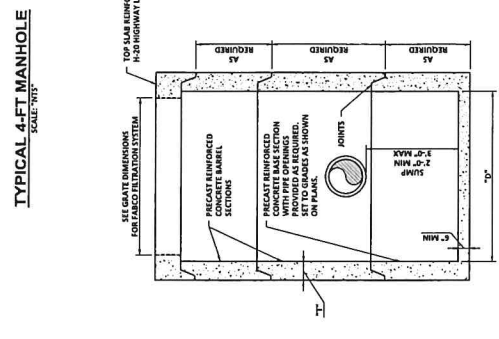

FLAT SLAB TOP CATCH BASIN  
SCALE: 1/2" = 1'-0"

DIAMETER (D)	MINIMUM WALL THICKNESS (T)
48"	4"
54"	5"
60"	6"

MANHOLE DIAMETER	MINIMUM WALL THICKNESS (T)
UP TO 36" O.D.	4"
UP TO 42" O.D.	5"
UP TO 48" O.D.	6"
UP TO 54" O.D.	7"
UP TO 60" O.D.	8"

NOTE: RIPRAP WIDTH SHALL BE EQUAL TO THE PIPE OUTSIDE Ø PLUS 4 FEET CENTERED ON PIPE







Town of Damariscotta, Maine

Waterfront Parking Lot Improvements  
60% Construction Cost Estimate - October 2021  
WP Project Number 20459

Site Preparation & Removals - Project Wide				
	Quantity	Unit	Unit Price	Cost
1 Mobilization/Demobilization	1	LS	\$174,000	\$174,000
2 Traffic Control	1	LS	\$20,000	\$20,000
3 Sediment and Erosion Controls	1	LS	\$18,000	\$18,000
4 Construction Layout	1	LS	\$5,000	\$5,000
5 Temporary Construction Fence	1000	LF	\$15	\$15,000
6 Test Pit Excavation and Backfill	10	EA	\$8,500	\$85,000
7 Excavation and Replacement of Unsuitable Material	270	CY*	\$90	\$24,300
Subtotal:				\$341,300
Flood Barrier				
	Quantity	Unit	Unit Price	Cost
1 Excavation	425	CY	\$50	\$21,250
2 Dewatering	1	LS	\$30,000	\$30,000
3 Sheet Pile Wall	19250	SF	\$65	\$1,251,250
4 Concrete Wall Cap	475	CY	\$380	\$180,500
5 Concrete Form Liner	2	LS	\$125,000	\$250,000
6 Flood Barrier Openings	300	SF	\$320	\$96,000
7 Deployable Flood Wall	1	LS	\$60,000	\$60,000
Subtotal:				\$1,824,000
Stormwater				
	Quantity	Unit	Unit Price	Cost
1 Excavation	2700	CY	\$50	\$135,000
2 Dewatering	1	LS	\$45,000	\$45,000
3 Underground Storage Tank	1	LS	\$320,000	\$320,000
4 Crushed Stone	800	CY	\$56	\$44,800
5 Geotextile and Geogrid	2000	SY	\$7	\$14,000
6 Storm Drain Manholes (4' diameter)	4	EA	\$8,000	\$32,000
7 Storm Drain Catch Basins (4' diameter structure with 3' sump)	8	EA	\$6,500	\$52,000
8 Fabco Storm Basins (2'x4')	8	EA	\$1,900	\$15,200
9 HDPE Storm Drain Pipe (15")	120	LF	\$110	\$13,200
10 HDPE Storm Drain Pipe (18")	317	LF	\$200	\$63,400
11 HDPE Storm Drain Pipe (24")	80	LF	\$335	\$26,800
12 Inline Check Valve (18")	2	EA	\$6,000	\$12,000
13 Inline Check Valve (24")	1	EA	\$8,000	\$8,000
Subtotal:				\$776,600
Parking Lot Improvements				
	Quantity	Unit	Unit Price	Cost
1 Sawcut Bituminous Pavement	950	LF	\$3	\$2,850
2 Reclaim Pavement Surface	8150	SY	\$7	\$57,050
3 Subbase (8" Gravel)	1830	CY	\$15	\$27,450
4 Asphalt Paving (3" Depth)	1350	TON	\$180	\$243,000
5 Handplaced Patterned Parking Stalls at Damariscotta Center	7	TONS	\$350	\$2,450
6 Thermal Plastic Pavement Marking for Crosswalks	1	LS	\$2,000	\$2,000
7 Parking Directional Signs	1	LS	\$2,500	\$2,500
8 Excavation for Placement of Taco Alley Pavers (15" Depth)	35	CY	\$50	\$1,750
9 Type A Gravel for Taco Alley Pavers (14" Depth)	28	CY	\$50	\$1,400
10 Sand and Pavers for Taco Alley (1" Depth of Sand)	585	SF	\$40	\$23,400
11 Excavation for Sidewalk to Water Street	30	CY	\$50	\$1,500
12 Type A Gravel for Sidewalk to Water Street	30	CY	\$50	\$1,500
13 Handplaced Paving for Sidewalk to Water Street	10	TONS	\$325	\$3,250
14 Loam and Seed	200	SF	\$4	\$800
15 Granite Curb	100	LF	\$70	\$7,000
16 Granite Bollards	10	EA	\$1,500	\$15,000
Subtotal:				\$392,800

### STRAIGHT GRANITE CURB

1. GRANITE CURB SHALL BE SET ON A 4" THICK CONCRETE SLAB ON GRADE. THE CURB SHALL BE 4" HIGH AND 12" WIDE. THE CURB SHALL BE SET ON A 4" THICK CONCRETE SLAB ON GRADE. THE CURB SHALL BE 4" HIGH AND 12" WIDE. THE CURB SHALL BE SET ON A 4" THICK CONCRETE SLAB ON GRADE. THE CURB SHALL BE 4" HIGH AND 12" WIDE.

### TYPICAL LIGHT POLE FOUNDATION DETAIL IN PAVEMENTS

1. LIGHT POLE FOUNDATION SHALL BE 18" DIA. CONCRETE. THE FOUNDATION SHALL BE SET ON A 4" THICK CONCRETE SLAB ON GRADE. THE FOUNDATION SHALL BE 18" DIA. CONCRETE. THE FOUNDATION SHALL BE SET ON A 4" THICK CONCRETE SLAB ON GRADE.

### GROUNDCOVER / PERENNIAL PLANTING

1. PERENNIAL PLANTING SHALL BE SET ON A 4" THICK CONCRETE SLAB ON GRADE. THE PLANTING SHALL BE 4" HIGH AND 12" WIDE. THE PLANTING SHALL BE SET ON A 4" THICK CONCRETE SLAB ON GRADE. THE PLANTING SHALL BE 4" HIGH AND 12" WIDE.

### SHRUB PLANTING

1. SHRUB PLANTING SHALL BE SET ON A 4" THICK CONCRETE SLAB ON GRADE. THE PLANTING SHALL BE 4" HIGH AND 12" WIDE. THE PLANTING SHALL BE SET ON A 4" THICK CONCRETE SLAB ON GRADE. THE PLANTING SHALL BE 4" HIGH AND 12" WIDE.

### TREE PLANTING

1. TREE PLANTING SHALL BE SET ON A 4" THICK CONCRETE SLAB ON GRADE. THE PLANTING SHALL BE 4" HIGH AND 12" WIDE. THE PLANTING SHALL BE SET ON A 4" THICK CONCRETE SLAB ON GRADE. THE PLANTING SHALL BE 4" HIGH AND 12" WIDE.

### STABILIZED DECOMPOSED GRANITE WALK

1. STABILIZED DECOMPOSED GRANITE WALK SHALL BE SET ON A 4" THICK CONCRETE SLAB ON GRADE. THE WALK SHALL BE 4" HIGH AND 12" WIDE. THE WALK SHALL BE SET ON A 4" THICK CONCRETE SLAB ON GRADE. THE WALK SHALL BE 4" HIGH AND 12" WIDE.

### PERVIOUS UNIT PAVER

1. PERVIOUS UNIT PAVER SHALL BE SET ON A 4" THICK CONCRETE SLAB ON GRADE. THE PAVER SHALL BE 4" HIGH AND 12" WIDE. THE PAVER SHALL BE SET ON A 4" THICK CONCRETE SLAB ON GRADE. THE PAVER SHALL BE 4" HIGH AND 12" WIDE.

### FLAG POLE FOUNDATION DETAIL

1. FLAG POLE FOUNDATION SHALL BE 18" DIA. CONCRETE. THE FOUNDATION SHALL BE SET ON A 4" THICK CONCRETE SLAB ON GRADE. THE FOUNDATION SHALL BE 18" DIA. CONCRETE. THE FOUNDATION SHALL BE SET ON A 4" THICK CONCRETE SLAB ON GRADE.

### TYPICAL BOLLARD LIGHT FOUNDATION DETAIL

1. TYPICAL BOLLARD LIGHT FOUNDATION SHALL BE 18" DIA. CONCRETE. THE FOUNDATION SHALL BE SET ON A 4" THICK CONCRETE SLAB ON GRADE. THE FOUNDATION SHALL BE 18" DIA. CONCRETE. THE FOUNDATION SHALL BE SET ON A 4" THICK CONCRETE SLAB ON GRADE.

### STABILIZED DECOMPOSED GRANITE WALK

1. STABILIZED DECOMPOSED GRANITE WALK SHALL BE SET ON A 4" THICK CONCRETE SLAB ON GRADE. THE WALK SHALL BE 4" HIGH AND 12" WIDE. THE WALK SHALL BE SET ON A 4" THICK CONCRETE SLAB ON GRADE. THE WALK SHALL BE 4" HIGH AND 12" WIDE.





PLANTING NOTES

1. THE CONTRACTOR SHALL MAINTAIN THE LOCATION OF ALL PLANTINGS.
2. THE CONTRACTOR SHALL MAINTAIN THE LOCATION OF ALL PLANTINGS.
3. THE CONTRACTOR SHALL MAINTAIN THE LOCATION OF ALL PLANTINGS.
4. THE CONTRACTOR SHALL MAINTAIN THE LOCATION OF ALL PLANTINGS.
5. THE CONTRACTOR SHALL MAINTAIN THE LOCATION OF ALL PLANTINGS.
6. THE CONTRACTOR SHALL MAINTAIN THE LOCATION OF ALL PLANTINGS.
7. THE CONTRACTOR SHALL MAINTAIN THE LOCATION OF ALL PLANTINGS.
8. THE CONTRACTOR SHALL MAINTAIN THE LOCATION OF ALL PLANTINGS.
9. THE CONTRACTOR SHALL MAINTAIN THE LOCATION OF ALL PLANTINGS.
10. THE CONTRACTOR SHALL MAINTAIN THE LOCATION OF ALL PLANTINGS.
11. THE CONTRACTOR SHALL MAINTAIN THE LOCATION OF ALL PLANTINGS.
12. THE CONTRACTOR SHALL MAINTAIN THE LOCATION OF ALL PLANTINGS.

PLANTING SCHEDULE

MARKETING PLANT	UPY FEET BOTANICAL NAME	SIZE	COMMENTS
①	Small shrub	1' x 1'	
②	Small shrub	1' x 1'	
③	Small shrub	1' x 1'	
④	Small shrub	1' x 1'	
⑤	Small shrub	1' x 1'	
⑥	Small shrub	1' x 1'	
⑦	Small shrub	1' x 1'	
⑧	Small shrub	1' x 1'	
⑨	Small shrub	1' x 1'	
⑩	Small shrub	1' x 1'	
⑪	Small shrub	1' x 1'	
⑫	Small shrub	1' x 1'	



Open >

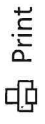

Print > Download

< Previous 5 of 6 Next > ⓘ



DATE PLOTTED: 10/1/2024 10:00 AM

PROJECT: STORMWATER IMPROVEMENTS DAMASCOTTA, MAINE

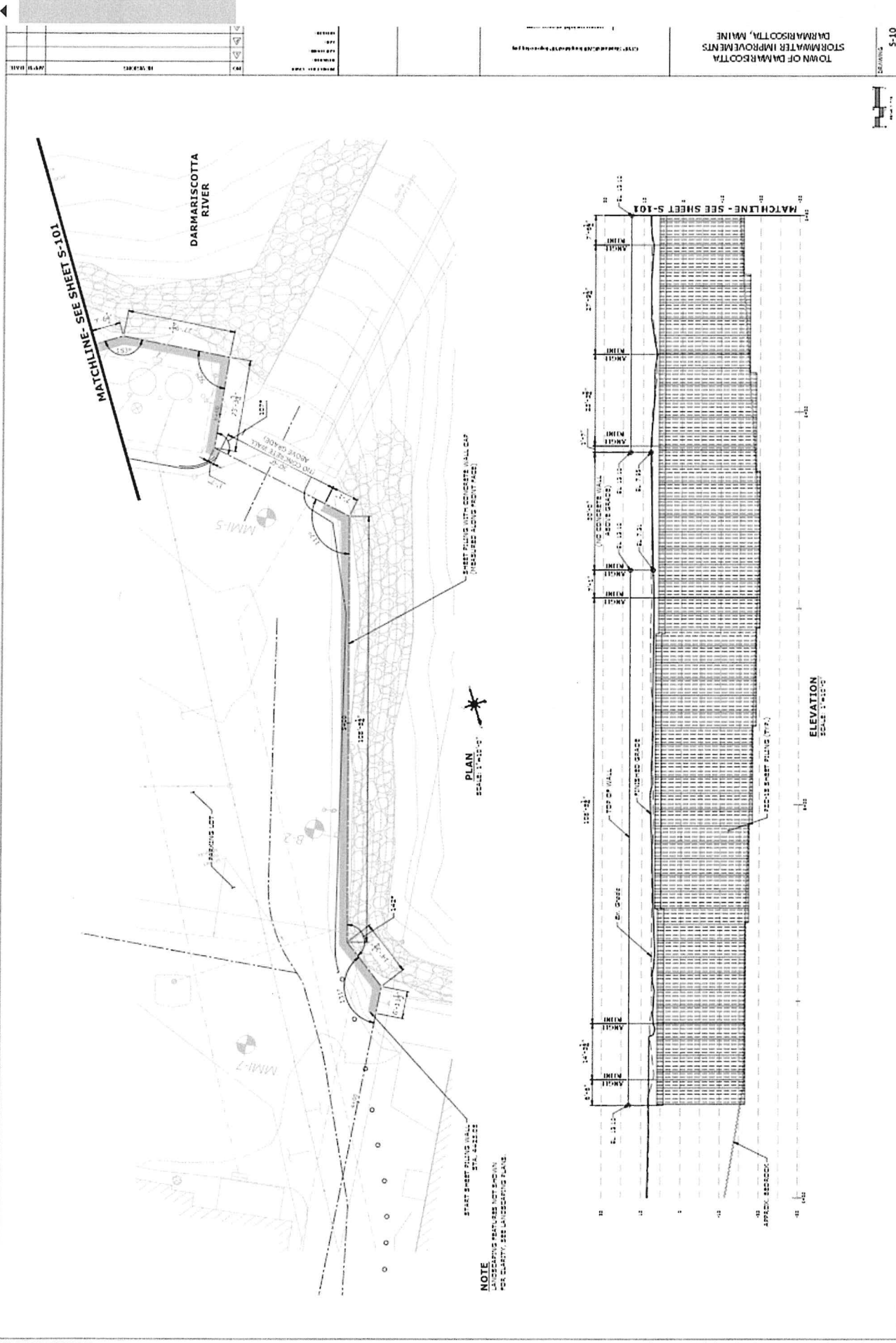

NO.	REVISION	DATE	BY	CHKD.
1				
2				
3				
4				
5				
6				
7				
8				
9				
10				
11				
12				
13				
14				
15				
16				
17				
18				
19				
20				
21				
22				
23				
24				
25				
26				
27				
28				
29				
30				
31				
32				
33				
34				
35				
36				
37				
38				
39				
40				
41				
42				
43				
44				
45				
46				
47				
48				
49				
50				
51				
52				
53				
54				
55				
56				
57				
58				
59				
60				
61				
62				
63				
64				
65				
66				
67				
68				
69				
70				
71				
72				
73				
74				
75				
76				
77				
78				
79				
80				
81				
82				
83				
84				
85				
86				
87				
88				
89				
90				
91				
92				
93				
94				
95				
96				
97				
98				
99				
100				

**NOTE**  
 SHADY AREAS INDICATE EXISTING CONSTRUCTION.  
 UNDESIRABLE FEATURES NOT SHOWN FOR CLARITY. SEE LANDSCAPE PLANS.

**PLAN**  
 SCALE: 1"=100'

**ELEVATION**  
 SCALE: 1"=10'

**TOWN OF DARMARISCOTTA**  
**STORMWATER IMPROVEMENTS**  
**DARMARISCOTTA, MAINE**

1307 (REVISED) 08/2013 (REVISED) 08/2013

Dear Selectman Fraser,

My name is Audrey Hufnagel. I am a sophomore at Lincoln Academy and a resident of Damariscotta. I am writing to ask you and the town Board of Selectmen to consider a resolution endorsing the Pine Tree Amendment.

The Pine Tree Amendment is a bill proposed by Senator Chloe Maxmin that will be considered in the upcoming session of the Maine legislature. It has received bipartisan support from the house and the senate. If passed, it would amend the Maine constitution to protect the right to clean air, clean water, and a healthy environment for all people.

Some of the things that I love most about Damariscotta and the state of Maine are the beautiful forests, rivers, lakes and other natural places that are so abundant. I love taking boat trips on the Damariscotta River, seeing the seals and the birds and the oyster farms, and I enjoy hiking on surrounding trails and seeing the diverse wildlife. I want all of this to be protected, and the Pine Tree Amendment will help do so.

Having the Pine Tree Amendment would benefit Damariscotta. Clean air, clean water and a healthy environment are good for the health of the people of Damariscotta, especially children. The Amendment also helps preserve the wildlife and land, which makes this area a more appealing place to live, as well as attracting tourists who fuel the local economy and support small business. Also, Damariscotta oyster farmers rely on clean water to grow oysters. All of these things would be protected by the Pine Tree Amendment.

The states of Pennsylvania and Montana both have amendments like the Pine Tree Amendment that have been used successfully to protect the environment and stop environmentally harmful projects.

I understand that the Damariscotta Board of Selectmen do not usually consider endorsements such as this, but I believe that this bill is crucial to the future of our town and our state. Two other municipalities, Brunswick and Camden, have passed similar resolutions. Voting in favor of this resolution would not bind the town of Damariscotta to anything, but it would signal local support for this issue, which would help get the bill passed. I therefore urge you to consider passing a resolution in support of the Pine Tree Amendment.

Sincerely,  
Audrey Hufnagel

P.S. Below is a sample script for a resolution about the Pine Tree Amendment. I do not know how resolutions are formatted in Damariscotta, but this includes some of the language that could be included in a possible resolution.

**RESOLUTION IN SUPPORT OF A “PINE TREE AMENDMENT” TO  
THE MAINE STATE CONSTITUTION**

WHEREAS, the right of people in Maine to a clean and healthy environment is not given any protection in the State of Maine’s Constitution;

WHEREAS, a clean and healthy environment sustains healthy lives and is fundamental to preserving Maine’s heritage for future generations, as well as protecting industries that depend on natural resources;

WHEREAS, the State of Maine has a long history of environmental protection and leadership to protect the health and environment of people in Maine;

WHEREAS, while environmental laws are designed to manage pollution, clean up and remediate contamination, and conserve natural resources, these laws do not support the notion that a clean and healthy environment is a fundamental, inalienable right;

WHEREAS, there are still a multitude of issues threatening Maine’s water, air, natural resources, such as climate change; emerging contaminants, such as PFAS and PFOA, in our drinking water supplies; poor to failing air quality; and disproportionate environmental impacts on environmental justice and frontline communities.

WHEREAS, in recognition of these facts, the Pine Tree Amendment (LD489) has been introduced in the Maine State Senate and House by Senator Chloe Maxmin, and among those co-sponsoring are Senator Richard Bennett, Senator Russell Black, Representative Bill Pluecker, Representative H. Landry, Representative Margaret O’Neil, Representative Laurie Osher, and Representative Rachel Talbot Ross on a tri-partisan basis. The bill states:

*“The people of the State have the right to a clean and healthy environment and to the preservation of the natural, cultural and healthful qualities of the environment. The State may not infringe upon these rights. The State shall conserve, protect and maintain the State’s natural resources, including, but not limited to, its air, water, land and ecosystems for the benefit of all the people, including generations yet to come.”*

WHEREAS, in recognition that to enact a Pine Tree Amendment in the Maine Constitution the above-mentioned bill must be passed by the Maine State Legislature and then be voted on as part of a statewide referendum;

WHEREAS, if the Pine Tree Amendment is passed by the Senate and the House, and if it is agreed to by the voters in a public question ballot referendum, this "Pine Tree Amendment" will be added to Article 1, the Declaration of Rights, of the Maine State Constitution;

WHEREAS, the town of Damariscotta hereby supports the Pine Tree Amendment (LD489); so that the voters may choose whether to add environmental rights to the Declaration of Rights of the Maine State Constitution, and further

RESOLVED, that the town of Damariscotta supports the passage of the Pine Tree Amendment by the Maine State Legislature in 2022 in time to be on the ballot in November 2022;

RESOLVED, that the town of Damariscotta encourages its County based legislative delegation to support LD489 for full passage by the Senate and House, so that the voters of our great State and great County may choose whether to add the right to a clean and healthy environment to the Declaration of Rights of the Maine State Constitution;

RESOLVED, that a copy of this resolution be forwarded to our State Legislative Delegation, the Pine Tree Amendment coalition\*, and county elected officials.

\*Pine Tree Amendment coalition: [pinetreeamendment@gmail.com](mailto:pinetreeamendment@gmail.com)